

# C-LOK

C-LOK Instrument Valve Co.,Ltd.

*Gauge Valves and Instrument Manifolds*

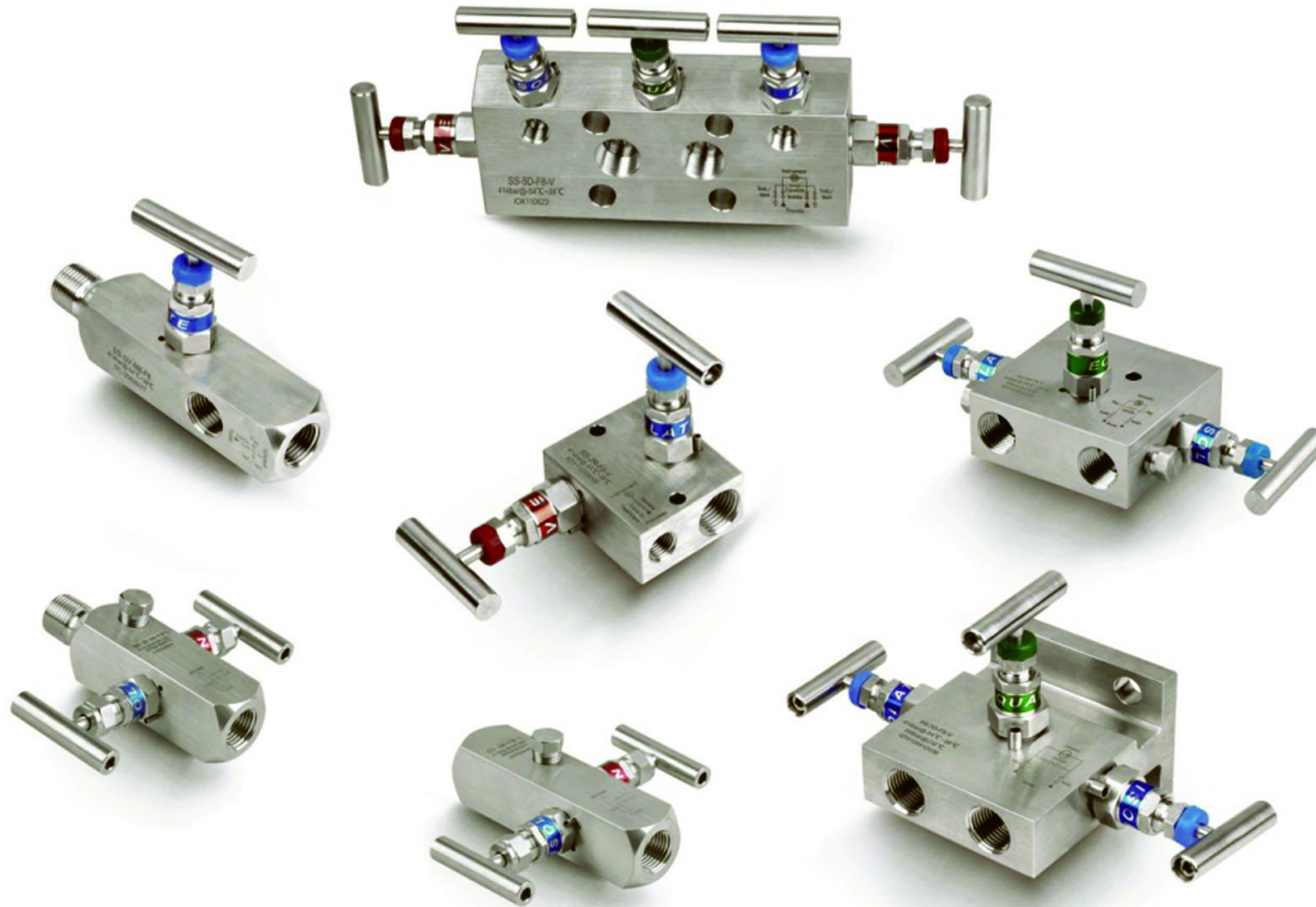

# C-LOK

## Contents

02 Two-Valve Manifolds



06 Three-Valve Manifolds



08 Five-Valve Manifolds



10 Gauge Valves



## Features

- Pressure up to 6000 psig(414 bar) for standard stainless steel body
- Temperature for PTFE packing from -65°F to 450°F (-54°C to 232°C)
- Temperature for Grafoil packing from -65°F to 1200°F (-54°C to 649°C)
- Packing below stem thread isolates the thread lubricant from the media
- Back seating design protects the packing in fully open position
- Non-rotating stem tip
- 100% factory tested
- Orifice: 0.157"(4.0mm), CV: 0.35

## Standard Materials of Construction

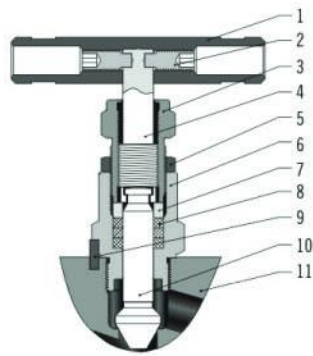

Handle color codes for functions:  
 BLACK=Isolate/block  
 RED=Test/vent  
 GREEN=Equalize

Item	Part	Valve Body Material		
		316 SS	Alloy 400	Alloy C-276
1	Handle	Anodized aluminum		
2	Set Screw	Nickel cadmium-plated steel		
3	Packing Bolt	321 SS/A276		
4	Upper Stem	316 SS/A276		
5	Lock Nut	316 SS/B783		
6	Bonnet	316 SS/A479	Alloy R-405/B164	Alloy C-276/B574
7	Gland	316 SS/A276		
8	Packing	PTFE or PEEK or graphite		
9	Lock Pin	304 SS/A276		
10	Lower Stem	Chrome-plated 316 SS/A276	Alloy R-405/B164	Alloy C-276/B574
11	Body	316 SS/A479 316 SS/A182	Alloy 400/B164, B127,B564	Alloy C-276/B564
	Lubricant	Molybdenum disulfide-based		

## Technical Data

Temperature		Valve body material	
°F	°C	316 SS	Carbon Steel
		Working pressure, psig(bar)	
-65~-20	-53~-28	6000(414)	—
-20~100	-28~37	6000(414)	3000(207)
200	93	5160(356)	2730(188)
250	121	4910(338)	2695(185)
300	148	4660(321)	2660(183)
350	176	4470(307)	2615(180)
400	204	4280(295)	
450	232	4130(285)	
500	260	3980(274)	
600	315	3760(259)	
650	343	3690(254)	
700	371	3600(248)	
750	399	3510(242)	
800	426	3460(238)	
850	454	3380(232)	
900	482	3280(225)	
950	510	3220(221)	
1000	538	3030(208)	
1050	566	3000(207)	
1100	593	2685(184)	
1150	621	2285(157)	
1200	649	1715(118)	

## Features

- Two valves in one block for isolation, calibration, test and bleeding of instruments.

Basic Model Number	Inlet / process	Outlet / instrument	Test / vent
-2D-F8-A	1/2" Female NPT	Flange(MSS)	1/4" Female NPT
Flange Seal and Bolt Kit: PTFE(or Grafoil) sealing rings + 7/16-20UNF Bolts			

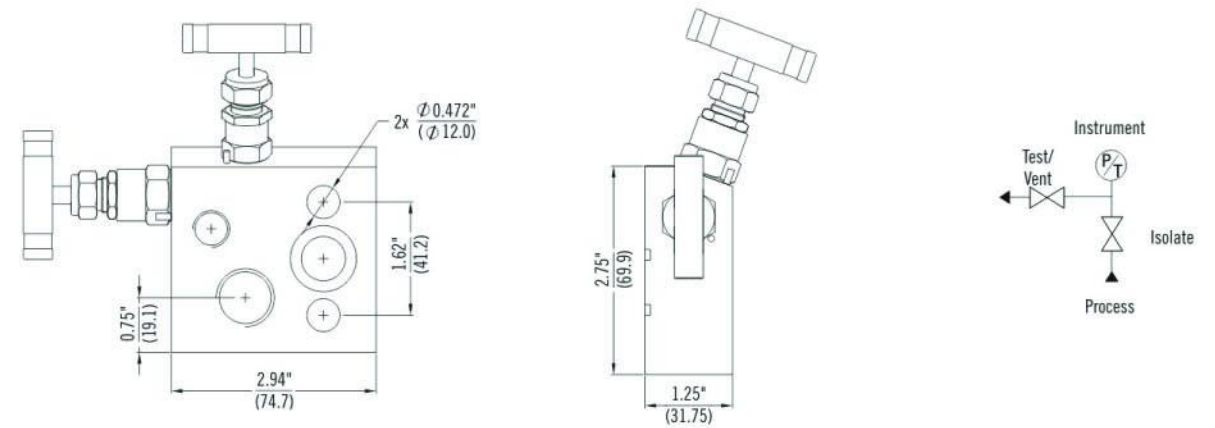

Basic Model Number	Inlet / process	Outlet / instrument	Test / vent
-2D-F8-A	1/2" Female NPT	Flange(MSS)	1/4" Female NPT
Flange Seal and Bolt Kit: PTFE(or Grafoil) sealing rings + 7/16-20UNF Bolts			

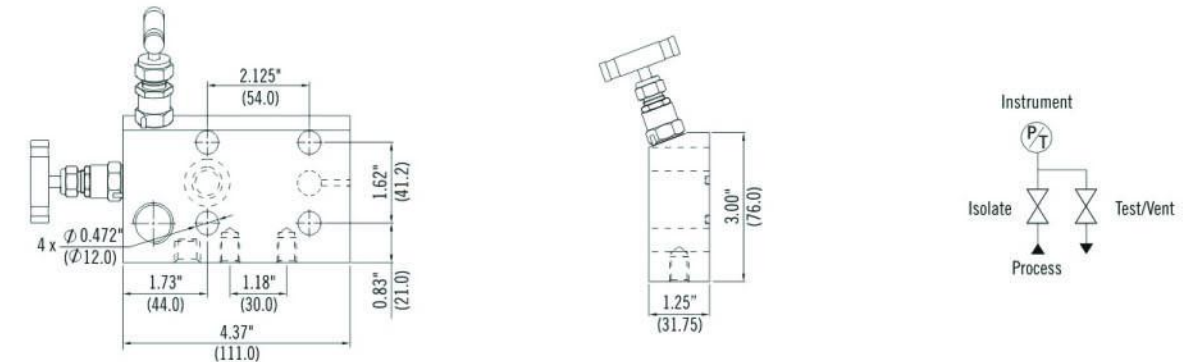

Basic Model Number	Inlet / process	Outlet / instrument	Test / vent
-2D-F8-L	1/2" Female NPT	Flange(MSS)	1/4" Female NPT
Flange Seal and Bolt Kit: PTFE(or Grafoil) sealing rings + 7/16-20UNF Bolts			

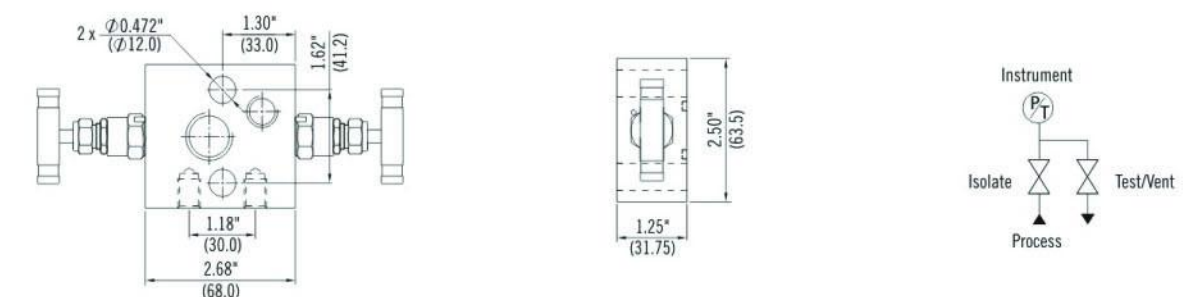

## Two-Valve Manifolds

Basic Model Number	Inlet / process	Outlet / instrument	Test / vent
-2D-F8-H	1/2" Female NPT	Flange(MSS)	1/4" Female NPT

Flange Seal and Bolt Kit: PTFE(or Grafoil) sealing rings + 7/16-20UNF Bolts

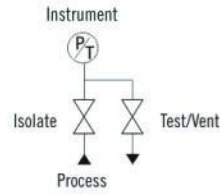
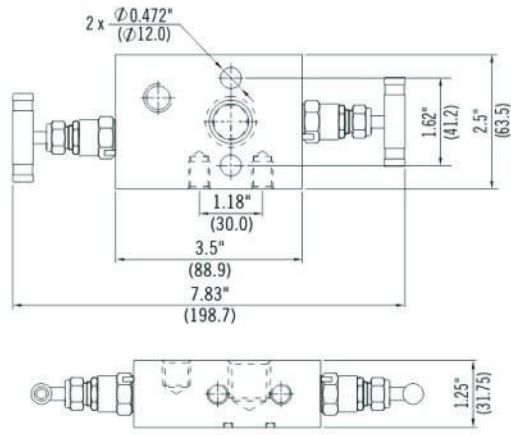

Basic Model Number	Inlet / process	Outlet / instrument	Test / vent
-2D-F8-C	1/2" Female NPT	Flange(MSS)	1/4" Female NPT

Flange Seal and Bolt Kit: PTFE(or Grafoil) sealing rings + 7/16-20UNF Bolts

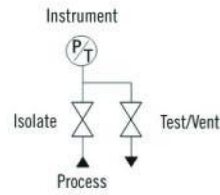
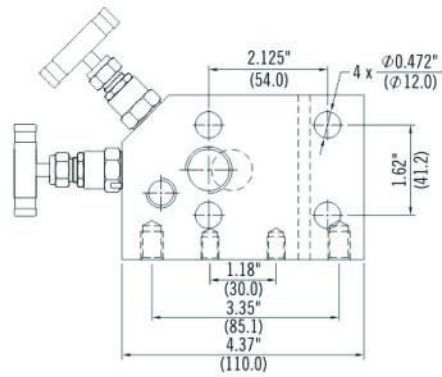

Basic Model Number	Inlet / process	Outlet / instrument	Test / vent
-2R-F8-M8-H	1/2" Male NPT	1/2" Female NPT	1/4" Female NPT

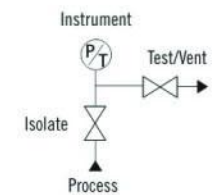
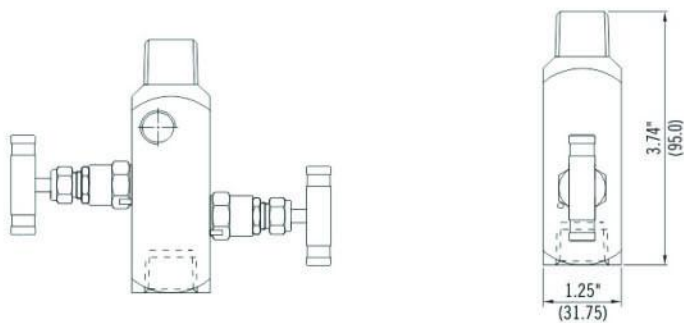

## Two-Valve Manifolds

Basic Model Number	Inlet / process	Outlet / instrument	Test / vent
-2R-F8-V	1/2" Female NPT	1/2" Female NPT	1/4" Female NPT

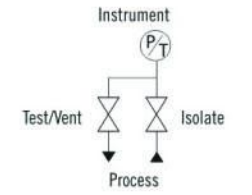
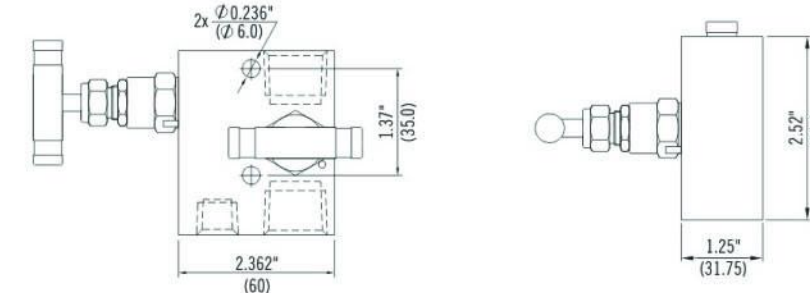

Basic Model Number	Inlet / process	Outlet / instrument	Test / vent
-2R-F4-A	1/4" Female NPT	1/4" Female NPT	1/4" Female NPT

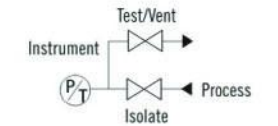
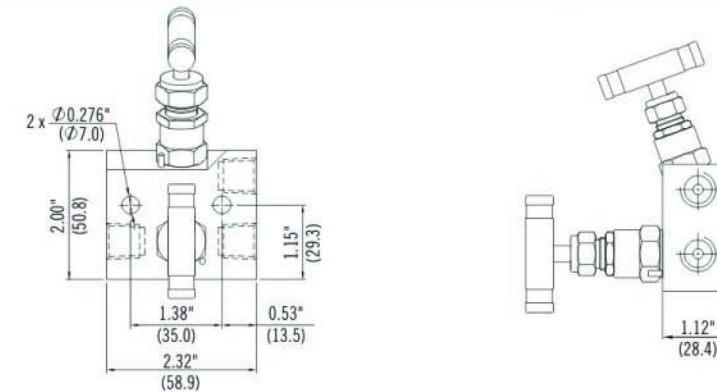

Basic Model Number	Inlet / process	Outlet / instrument	Test / vent
-2R-F4-C	1/4" Female NPT	1/4" Female NPT	1/4" Female NPT

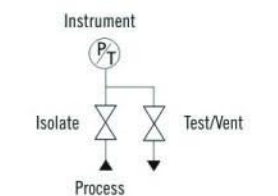
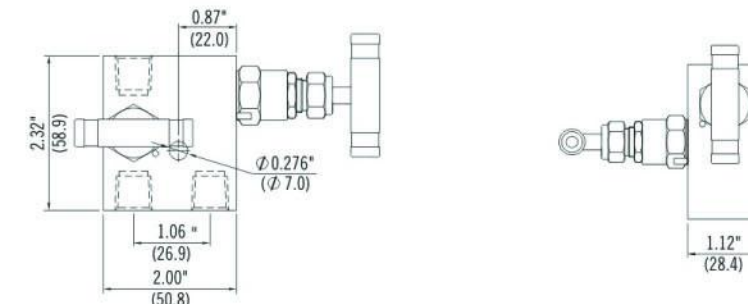

## Two-Valve Manifolds

Basic Model Number	Inlet / process	Outlet / instrument	Test / vent
-2R-F8-L	1/2" Female NPT	1/2" Female NPT	1/4" Female NPT

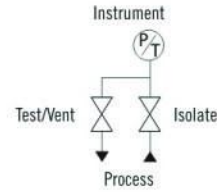
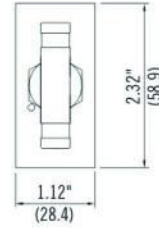
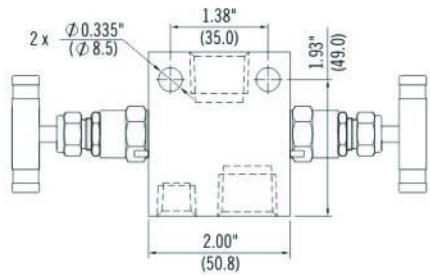

## Three-Valve Manifolds

### Features

- Three valves in one block for isolation, equalization, bleeding of instruments.

Basic Model Number	Inlet / process	Outlet / instrument	Test / vent
-3D-F8-L	1/2" Female NPT	Flange(MSS)	Optional

Flange Seal and Bolt Kit: PTFE(or Grafoil) sealing rings + 7/16-20UNF Bolts

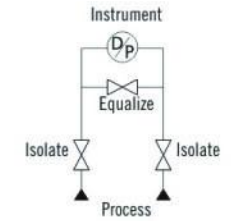
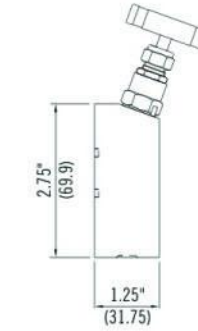
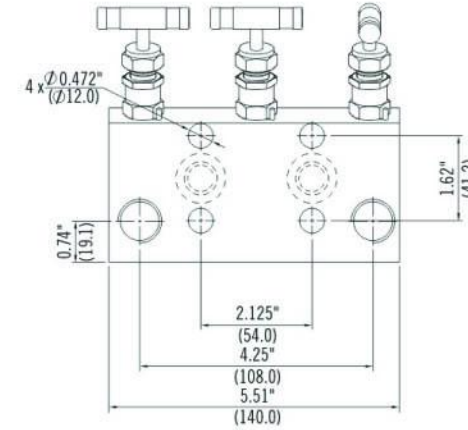

Basic Model Number	Inlet / process	Outlet / instrument	Test / vent
-3D-F8-A	1/2" Female NPT	Flange(MSS)	Optional
-3D-S8-A	1/2" OD	Flange(MSS)	Optional

Flange Seal and Bolt Kit: PTFE(or Grafoil) sealing rings + 7/16-20UNF Bolts

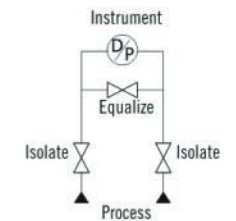
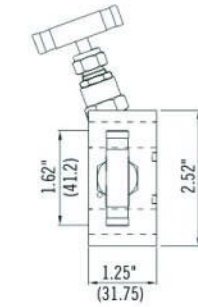
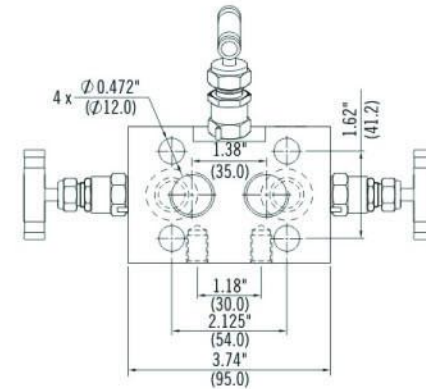

Basic Model Number	Inlet / process	Outlet / instrument	Test / vent
-3D-F8-V	1/2" Female NPT	Flange(MSS)	Optional

Flange Seal and Bolt Kit: PTFE(or Grafoil) sealing rings + 7/16-20UNF Bolts

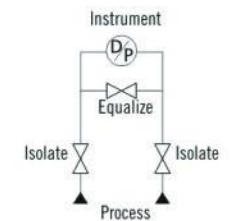
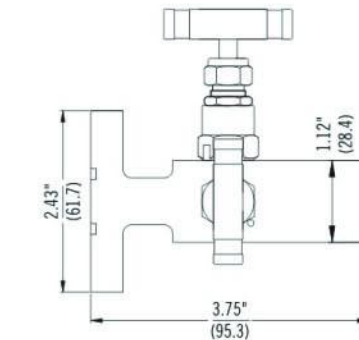
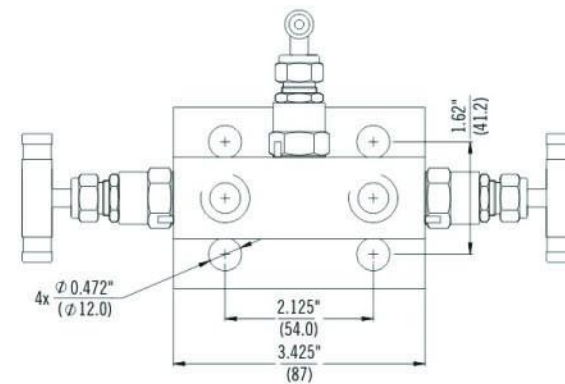

## Three-Valve Manifolds

Basic Model Number	Inlet / process	Outlet / instrument	Test / vent
-3D-F8-C	1/2" Female NPT	Flange(MSS)	Optional
-3D-S8-C	1/2" OD	Flange(MSS)	Optional

Flange Seal and Bolt Kit: PTFE(or Grafoil) sealing rings + 7/16-20UNF Bolts

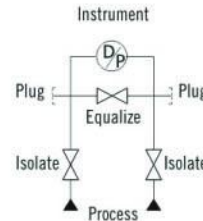
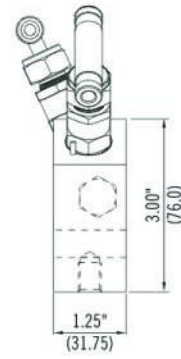
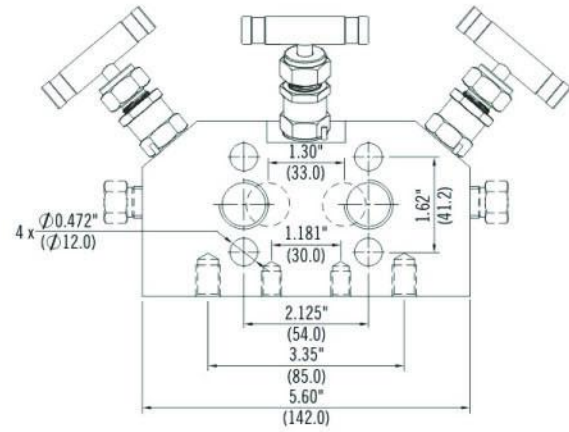

Basic Model Number	Inlet / process	Outlet / instrument	Test / vent
-3R-F8-V	1/2" Female NPT	1/2" Female NPT	Optional
-3R-S8-V	1/2" OD	1/2" OD	Optional

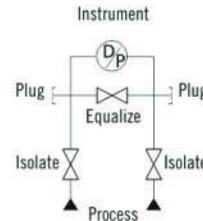
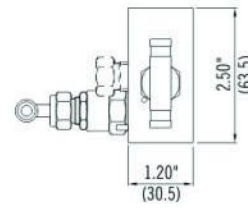
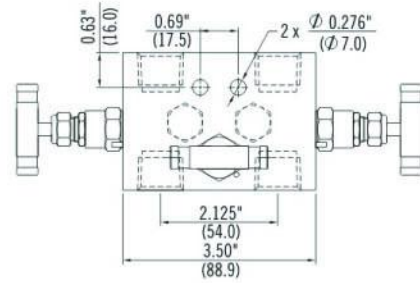

## Five-Valve Manifolds

### Features

- Five valves in one block for isolation, equalization, testing and venting of instruments

Basic Model Number	Inlet / process	Outlet / instrument	Test / vent
-5D-F8-A	1/2" Female NPT	Flange(MSS)	1/4" Female NPT

Flange Seal and Bolt Kit: PTFE(or Grafoil) sealing rings + 7/16-20UNF Bolts

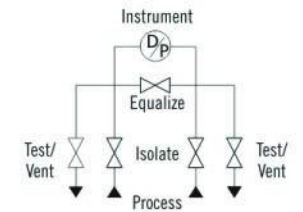
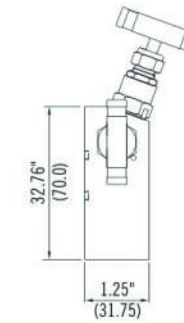
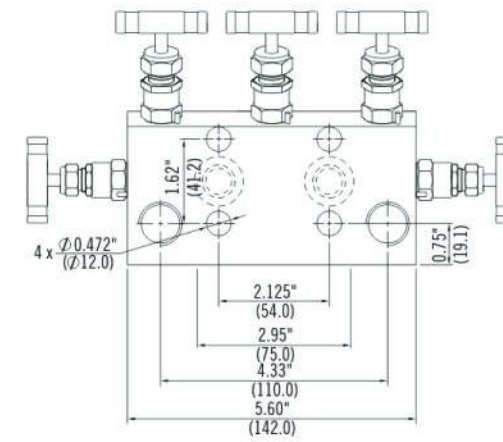

Basic Model Number	Inlet / process	Outlet / instrument	Test / vent
-5D-F8-C	1/2" Female NPT	Flange(MSS)	1/4" Female NPT
-5D-S8-C	1/2" OD	Flange(MSS)	1/4" Female NPT

Flange Seal and Bolt Kit: PTFE(or Grafoil) sealing rings + 7/16-20UNF Bolts

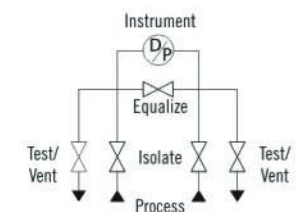
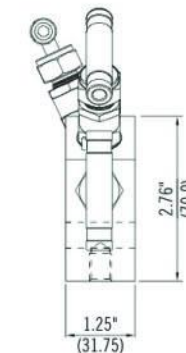
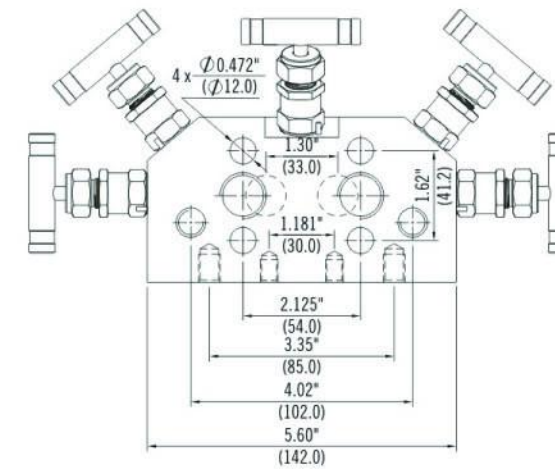

# Five-Valve Manifolds

# Gauge Valves

Basic Model Number	Inlet / process	Outlet / instrument	vent	Test
-5D-F8-B	1/2" Female NPT	Flange(MSS)	1/4" Female NPT	Option
-5D-S8-B	1/2" OD	Flange(MSS)	1/4" Female NPT	Option

Flange Seal and Bolt Kit: PTFE(or Grafoil) sealing rings + 7/16-20UNF Bolts

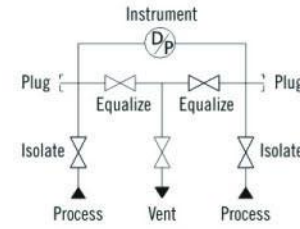
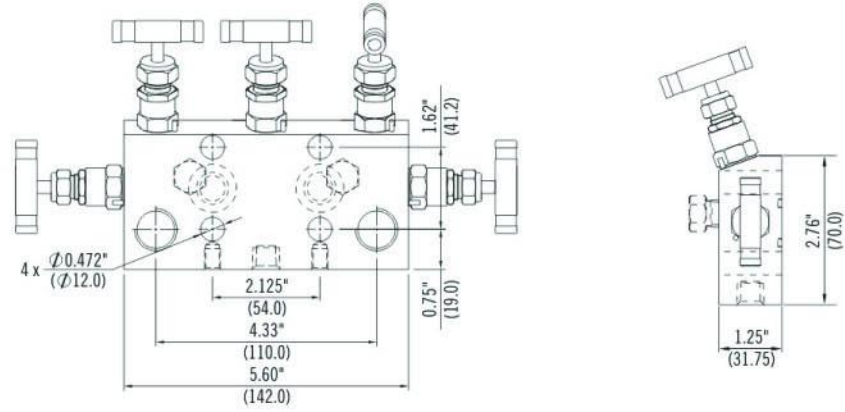

Basic Model Number	Inlet / process	Outlet / instrument	Test / vent
-5R-F8-A	1/2" Female NPT	1/2" Female NPT	1/4" Female NPT

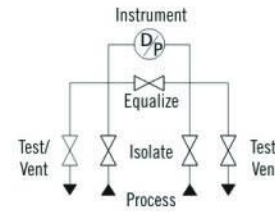
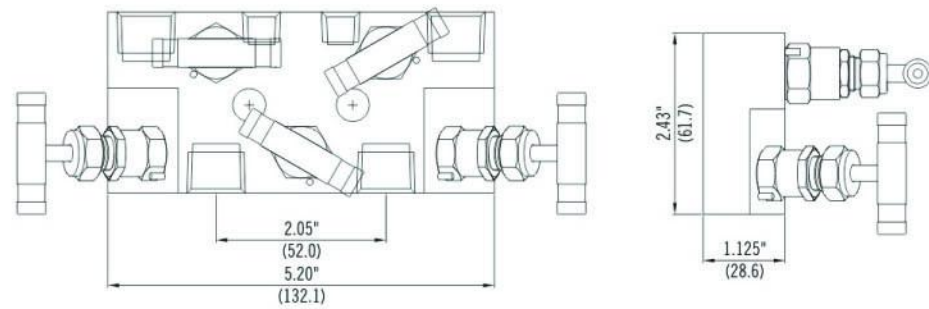

Basic Model Number	Inlet / process	Outlet / instrument	Test / vent
-5R-F8-L	1/2" Female NPT	1/2" Female NPT	1/4" Female NPT
-5R-S8-L	1/2" OD	1/2" Female NPT	1/4" Female NPT

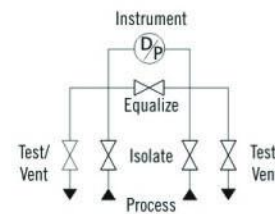
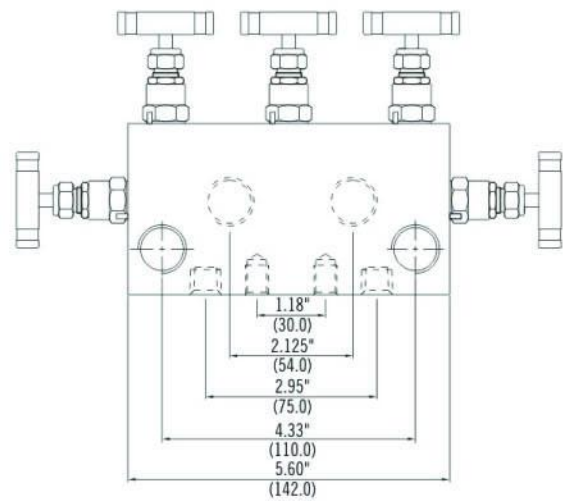

## Features

- A valve with 3 outlets in one block for isolation, bleeding of instruments.

Basic Model Number	Inlet / process	Outlet / instrument	Test / vent
-GV-M8-F8	1/2" Male NPT	1/2" Female NPT	1/2" Female NPT

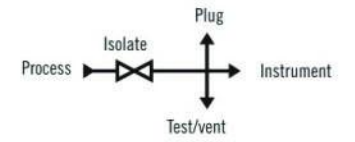
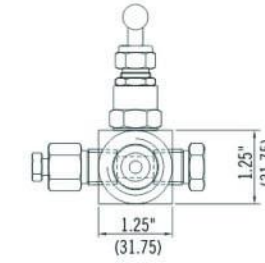
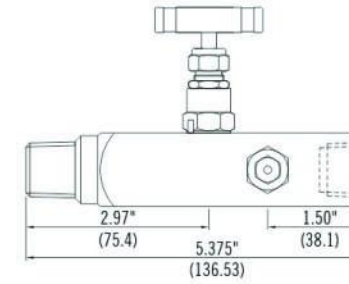

Basic Model Number	Inlet / process	Outlet / instrument	Test / vent
-GV-M8-F8-E	1/2" Male NPT	1/2" Female NPT	1/2" Female NPT

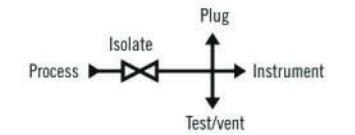
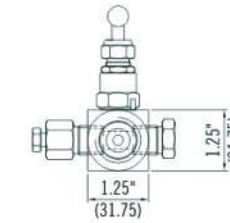
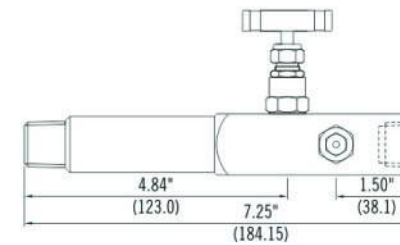

Basic Model Number	Inlet / process	Outlet / instrument
-GV-M8-F8-C	1/2" Male NPT	1/2" Female NPT

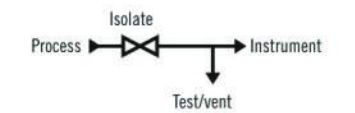
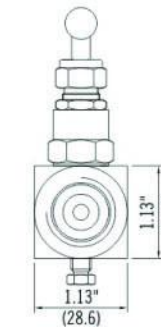
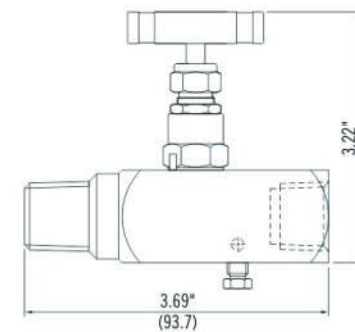

**SS - 3D - F 8 - A - G - TP**

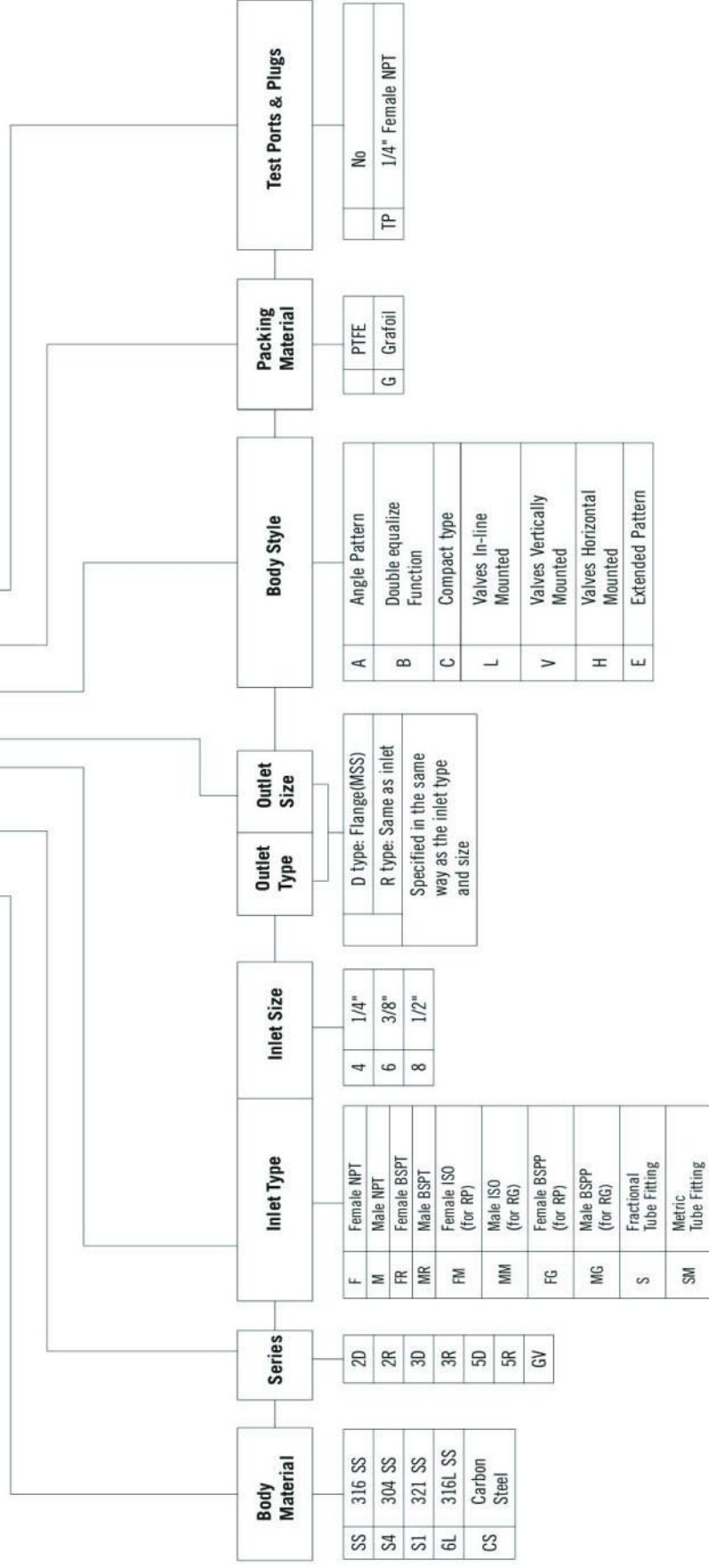

**Remark:**

- The standard material of bolts is carbon steel